

PSEUDO-ADIABATIC CALORIMETRY

F. Grønlund

LABORATORY OF PHYSICAL CHEMISTRY, H. C. ØRSTED INSTITUTE, UNIVERSITY OF COPENHAGEN, 5 UNIVERSITETSPARKEN, DK-2100 COPENHAGEN, DENMARK

A procedure is described for dealing with the error sources inherently present in any real calorimeter: work of power P_s input from stirrer and possibly temperature sensor, and heat exchange at a rate $-G(T-T_c)$ where T and T_c are the temperatures of calorimeter and surroundings respectively. The constants P_s and G are calculated from a period of thermal decay, and afterwards are used to correct the entire run. A calorimeter was designed with high thermal homogeneity and used in a test. The curve of calculated temperature exactly traces the heater energy, even after 5 h, with a standard deviation of about 1 mK. The relative error in C_p is less than 1/1000.

Keywords: adiabatic, calorimetry, correction, integration

Introduction

In ordinary calorimetry two sources of error are always present which ultimately set a limit to the precision obtainable. One is the small but steady power P_s delivered by the stirrer, possibly assisted by the temperature sensor, and the other is the heat flow that takes place at a rate ϕ between calorimeter and surroundings, of temperature T and T_c respectively.

Consider an open calorimeter at constant pressure in which no change of composition takes place, and which therefore obeys the familiar equation $dH = C_p dT = \delta w' + \delta q$. The right-hand side of the equation sums up all useful work w' and heat q transferred to the calorimeter, including errors, while the left-hand side accounts for the enthalpy change associated with the change of state of the calorimeter. Hence, in the calibration phase when electrical work is delivered at a power P , it is incorrect to identify $C_p dT$ with $P dt$. In isoperibol calorimetry the constant power P_s may be corrected for by a shift in reference temperature, but the best way of treating the heat leak, Dickinson's method [1], is not very precise as it depends on the slope of the thermogram.

A new strategy is proposed for obtaining correct results, based on Tian's equation [2], recently re-evaluated [3, 4]. First, the constants of the calorimeter — the small but constant power P_s and the thermal conductance G that enters Newton's law of cooling $\dot{\varphi} = -G(T - T_s)$ — are evaluated from data obtained with zero calibration power. Next, all temperature readings taken during the entire calibration run are corrected using the two parameters.

For this a calorimeter is needed with the following properties and extra equipment: two linear, sensitive temperature sensors instead of one; a high degree of thermal uniformity in both the inner vessel and its surroundings (no hot or cold spots); a personal computer with a data acquisition board; and software for treating the data.

A calorimeter has been designed to meet these demands. A number of calibration runs of varying heat-pulse height and duration, all leading to the same heat capacity to within less than 1 in 1000, proved the method to be highly satisfactory, even for periods of up to 5 h or more.

Temperature equations

Let the state of the inner vessel plus contents be given by the constant pressure p , its temperature T and its heat capacity C_p , with no change of phase or composition taking place in it. After the small time interval δt_j during which useful work δw_j and heat δq_j are transferred to it, its change of state is given by

$$\delta H_j = C_p \delta T_j = \delta w_j + \delta q_j \quad (1)$$

The terms on the right side include

a) electrical work $P_j \delta t_j$ from the calibration heater at a power P_j that may vary from one interval to the next,

b) mechanical work from the stirrer and possibly electrical work from the temperature sensor, combining to give $P_s \delta t_j$ with constant P_s , and

c) heat exchanged with the surroundings $-G(T_j - T_c) \delta t_j$ according to Newton's law; T_c is the temperature of the surroundings. Inserting these contributions into Eq. (1) we get for the j 'th interval

$$C_p \delta T_j = P_j \delta t_j + P_s \delta t_j - G(T_j - T_c) \delta t_j \quad (j = 1, 2, \dots, n) \quad (2)$$

Equation (2) may be treated in either of two ways. Division by δt_j gives a set of n independent difference equations, based on $n + 1$ data sets:

$$\frac{\delta T_j}{\delta t_j} = P_j / C_p + P_s / C_p - (G / C_p)(T_j - T_c) \quad (3)$$

Since difference quotients may introduce large errors, this method is best suited for cases approaching heat flow calorimetry where $\delta T_j/\delta t_j$ becomes unimportant.

The alternative approach consists in numerical integration of Eq. (2). To find the status after the first k intervals, sum the terms from $j = 0$ to $j = k$:

$$C_p(T_k - T_0) = \sum_{j=0}^k P_j \delta t_j + P_s t_k - G \sum_{j=0}^k (T_j - T_{e_j}) \delta t_j \quad (4)$$

The physical equivalent to these n independent equations ($k = 1, 2, \dots, n$) is a set of experiments lasting from $j = 0$ to 1; from $j = 0$ to 2; ...; from $j = 0$ to n . When used in ordinary calorimetry, this way of treating Eq. (2) gives a precision higher by one or two orders of magnitude than the difference equation.

Equation (4) may be solved for T_k

$$T_k = T_0 + (1/C_p) \sum_{j=0}^k P_j \delta t_j + (P_s/C_p) t_k - (G/C_p) \sum_{j=0}^k (T_j - T_{e_j}) \delta t_j \quad (5)$$

The form of these linear equations is simply

$$T_k = a + b f_k + c t_k - d g_k \quad (k = 1, 2, \dots, n) \quad (6)$$

where the parameters $a = T_0$, $b = 1/C_p$, $c = P_s/C_p$, $d = G/C_p$ are constants to be determined while the quantities with subscript k are measured values, or sums of measured values. With $k = 1, 2$, up to perhaps several hundred, we have as many equations to determine some or all of the four parameters with the method of least squares [5].

When extended over an entire calibration run, with an initial rest period of $P = 0$, a heating period, and a period of thermal decay, all of the four constants may be determined in one operation. It was found that, owing to the temperature lag during heating, it is better to proceed in two steps: first a , c and d are calculated from data of the decay period alone; of these, a is a reference temperature of no further consequence. With c and d known, one may next calculate the temperature corrections for every stage k of the entire run $T_{\text{corr}_k} = c t_k - d g_k$. Subtracting this from the observed temperature one obtains the calculated temperature T_c

$$T_{e_k} = T_{\text{obs}_k} - T_{\text{corr}_k} = T_k - (c t_k - d g_k) \quad (7)$$

Since T_c is the temperature of the thermogram corrected for errors, it describes the values that would have been observed, had the calorimeter been adiabatic.

It is not surprising, therefore, that the curve $T_c(t)$ should consist of one horizontal, constant temperature T_i , a rising line of constant slope, and another horizontal line at temperature T_f , just as if no source of error were present. With a

knowledge of $w' = \sum P_j \delta t_j = C_p(T_f - T_i)$, C_p is readily determined. MathCAD software [6] was used in the calculations.

Experimental

The calorimeter, built to test the method in favourable conditions, was designed to ensure uniformity of temperature of the inner vessel T and of the surroundings T_e . A sketch is shown in Fig. 1. Constructional details will be published elsewhere [7].

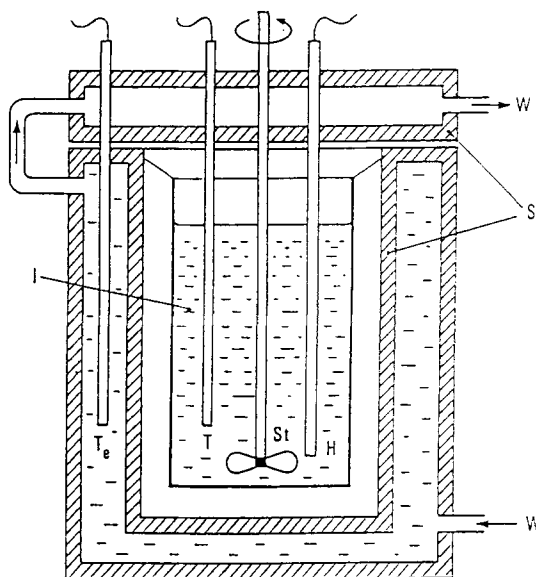

Fig. 1 Sketch of calorimeter. I, inner vessel, filled with 300 g decalin; H, electrical heater for calibration (100 Ω , Pt RTD, four leads); St, stirrer; T, T_e temperature sensors (Analog Devices AC 2626); S surroundings with circulating thermostat water W in all parts

Results

The thermogram $T_{\text{obs}}(t)$ of a simple, illustrative calibration run with one heat pulse only, separating two rest periods, is shown in Fig. 2a. It is seen to last for 5 h, including a rest period, a heating period lasting 1200.0 s and producing a temperature rise of nearly 4 K, and a decay period. A total of 300 data sets was stored during the run. Analysis of the data from the decay period, using Eq. (5)

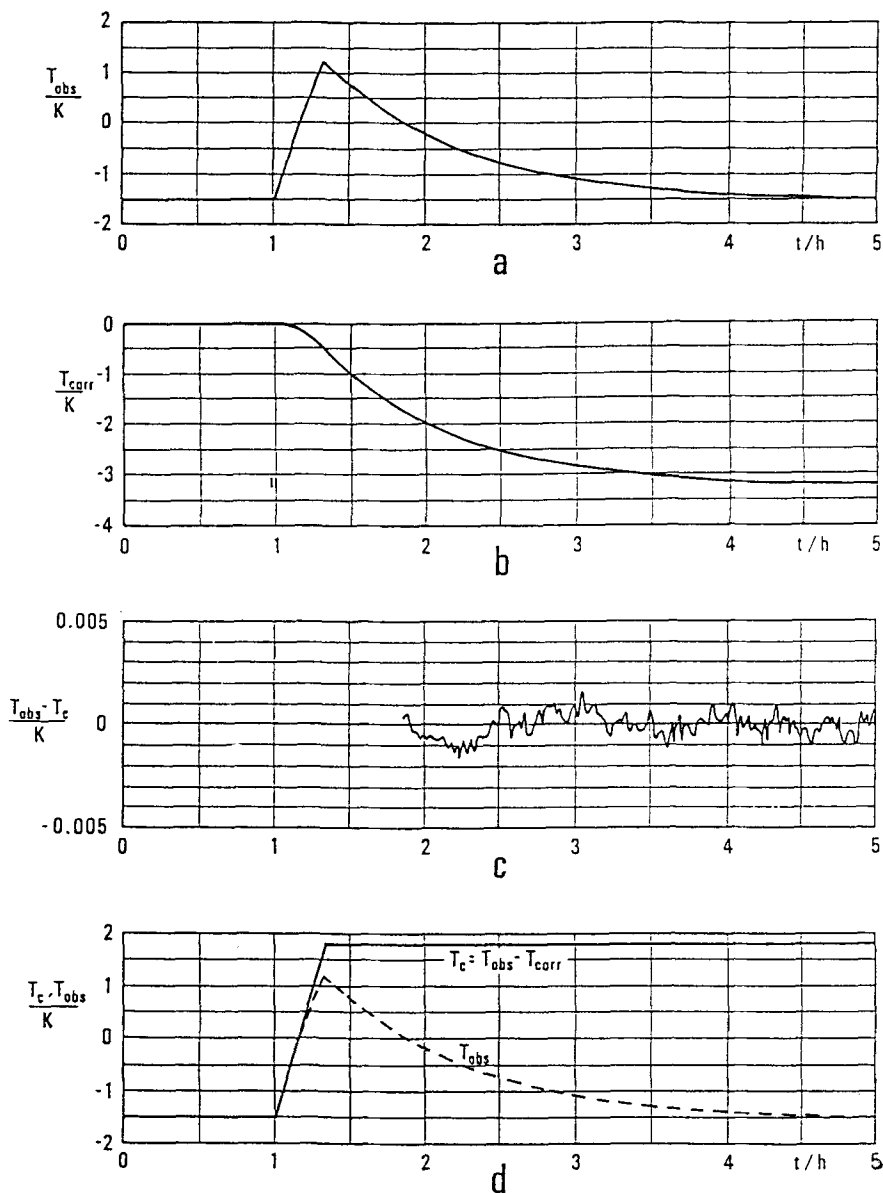

Fig. 2 Temperature curves for a calibration run. a) Observed temperature T_{obs} ; b) temperature correction T_{corr} ; c) $(T_{obs} - T_{corr})$ in the decay period; d) calculated temperature T_c (—) and observed temperature T_{obs} (---) for entire run

gave $P\sqrt{C_p} = 2.60 \cdot 10^{-5}$ K/s and $G/C_p = 3.094 \cdot 10^{-4} \text{ s}^{-1}$ (corresponding to a temperature relaxation time of about $3\frac{1}{4}$ h).

Using these values, the temperature correction T_{cor} was evaluated for each data set. The resulting curve, shown in Fig. 2b, gives the combined effect of constant power (small, positive, linear) and heat exchange (large, negative, exponentially decaying). After a few hours, the correction outweighs the measured temperature.

Figure 2c demonstrates the agreement between T_{obs} and T_{cor} during the decay period, being a plot of their difference. The calculated standard deviation is 0.6 mK.

Lastly, Fig. 2d shows a plot of the calculated temperature $T_c = T_{\text{obs}} - T_{\text{cor}}$ vs. time, with the original thermogram of Fig. 2a inserted for comparison. As expected, it shows two well-defined, constant levels T_i and T_f . The calibration work, read from the data, was $w' = 2.1407$ kJ, and the average temperature difference $(T_f - T_i) = 3.2945$ K, whence $C_p = 649.8$ J/K.

A series of seven calibration runs were made with the same filling but with varying pulse height and duration. The average heat capacity was found to be $C_p = 649.2$ J/K with a standard deviation of 0.5 J/K.

Conclusions

The method described offers a considerable gain in precision in ordinary calorimetry. For simplicity, only its application to calibration was shown, but the extension to measurement of enthalpy changes associated with change of composition is obvious, even with reactions lasting for hours. It also eliminates the need to make the calibration temperature curve have nearly the same shape as the one produced by a reaction. Comparison of T_{obs} with T_c gives an idea of the error that may be committed by uncritical use of the thermogram alone.

References

- 1 H. C. Dickinson, Bull. Bur. Stand. (U.S.), 11 (1914) 189.
- 2 A. Tian, J. Chim. Phys., 30 (1933) 665.
- 3 F. Grönlund, J. Chem. Thermodynamics, 22 (1990) 563.
- 4 F. Grönlund, Thermochim. Acta, 175 (1991) 63.
- 5 S. Brandt, Statistical and Computational Methods in Data Analysis, North-Holland; Amsterdam (1976).
- 6 MathSoft Inc., 201 Broadway, Cambridge, Massachusetts 02139, USA.
- 7 F. Grönlund, J. Chem. Thermodynamics, to be published.

Zusammenfassung — Es wird ein Verfahren zum Umgang mit Fehlerquellen beschrieben, die von Natur aus in allen Kalorimetern auftreten: die Arbeit P_s von Rührwerken und möglichen Temperaturfühlern, sowie Wärmeaustausch mit einer Geschwindigkeit von $-G(T-T_e)$, wo T bzw. T_e die Temperatur des Kalorimeters bzw. der Umgebung bedeutet. Die Konstanten P_s und G werden anhand eines Abschnittes des thermischen Abklingens berechnet und dann benutzt, um das ganze Experiment zu korrigieren. Es wurde ein Kalorimeter mit einer hohen thermischen Homogenität konstruiert und in einem Test eingesetzt. Die Kurve der berechneten Temperaturen folgt auch nach 5 Stunden exakt der Erhitzerenergie, die Standarddeviation beträgt dabei etwa 1 mK. Der relative Fehler für C_p liegt unter 1/1000.